

REVISIONS

REV	DESCRIPTION	DATE	APPR'D	TRACK
1	ADDED 54"	5/23/11	DAC	3523
2	EFV DIAMETER CHG. FROM 1-1/4 TO 1-5/16	12/12/11	DAC	3674
3	CHG. TO TWO PIECE DIFFUSER	12/4/14	DAC	4288

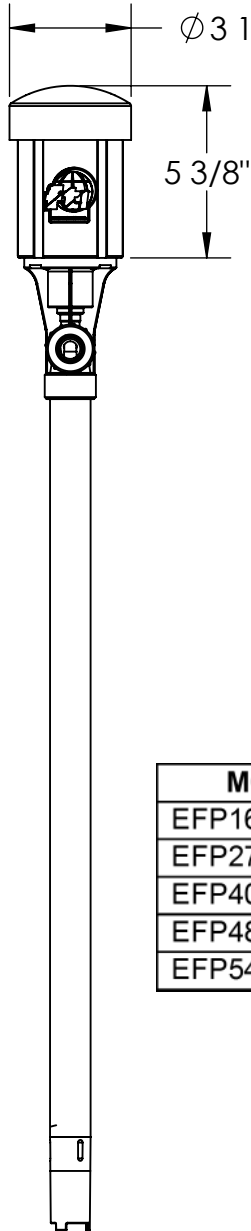

S4 AIR MOTOR

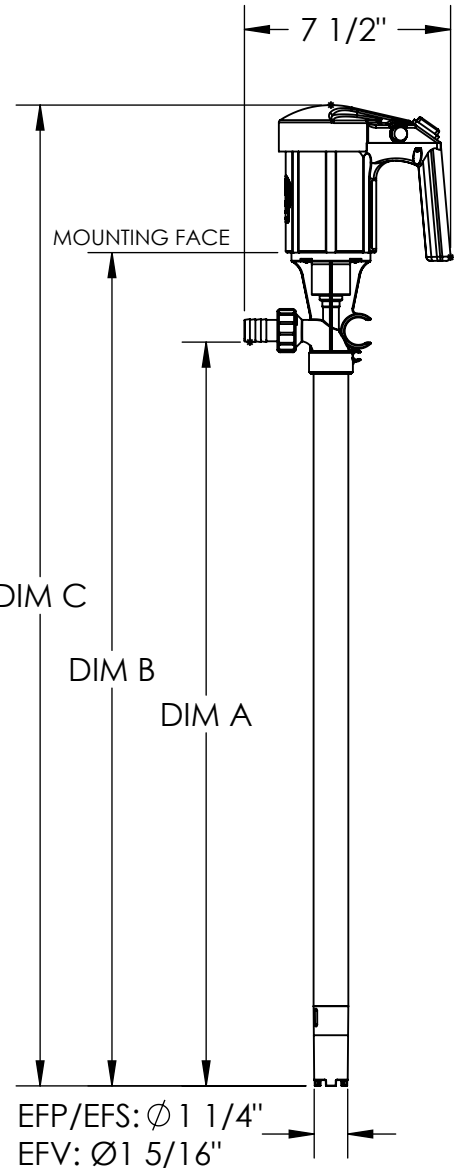
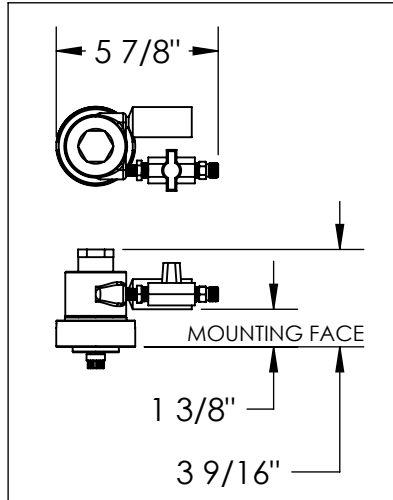

MODEL	DIM A	DIM B	DIM C
EFP16 & EFV16	16 1/8	19 3/8	24 3/4
EFP27 & EFV27	27 1/8	30 3/8	35 3/4
EFP40 & EFV40	40 1/8	43 3/8	48 3/4
EFP48 & EFV48	48 1/8	51 3/8	56 3/4
EFP54 & EFV54	54 1/8	57 3/8	62 3/4

MODEL	DIM A	DIM B	DIM C
EFS16	16	19 1/4	24 5/8
EFS27	27	30 1/4	35 5/8
EFS40	40	43 1/4	48 5/8
EFS48	48	51 1/4	56 5/8

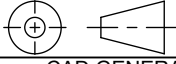
UNLESS OTHERWISE SPECIFIED		DISTRIBUTION BLOCK				921 GREENGARDEN ROAD ERIE, PENNSYLVANIA 16501		 PHONE: (814) 455-4478 FAX: (814) 455-8518		
DIMENSIONS ARE IN INCHES TOLERANCES ARE: .XXX ± .005 .XX ± .010 FRAC. ± 1/16 DEGREE ± 1° FINISH 125		DEPT	REC'D	DEPT	REC'D	PRODUCT: EF				
		PUMP ASSM		INJ MOLD		TITLE: OUTLINE DIMENSIONAL				
		STILL ASSM		PURCH		SIZE: A	PART NUMBER: R100649	REV. 3		
		WELD SHOP		SALES		SCALE: 1:6	SHEET 1 OF 1	CHECKED		
SIGNATURES	DATE	MACH SHOP	ADV	THIRD ANGLE PROJECTION						
DRAWN: DAC	11/4/09									
ENGR:				CAD GENERATED DRAWING, DO NOT MANUALLY UPDATE						
DO NOT SCALE DRAWING										